

ECO SENSORS, INC.

OZONE ANALYZER Model UV-100

INSTRUCTIONS FOR USE

GENERAL

The model UV-100 is a UV absorption analyzer designed specifically for ozone. It uses a mercury lamp filtered for absorption at 254 nm as is typical of other commercial instruments. The Eco Sensors, Inc., design is very compact and uses the latest digital microprocessor technology. The UV-100 covers three ranges: 0-1, 0-10 and 0-999 PPM. Its outputs are a LCD digital display, 0-2.5 VDC, 4-20 mA, and a time and date stamped digital data stream for external readout and data logging. The data output are via serial port and USB. There is also an internal data logger which can store and forward approximately 36 hours of data. The theory of operation is described in Appendix D.



Panel LEDs indicate "on", low lamp output, low flow rate, and the ozone concentration at the sampling point exceeds 0.1 PPM.

The instrument is conditionally warranted for one year. Read the warranty statement at the end of this manual.

OPERATION

Plug the AC adapter into AC power and plug the adapter's output plug into the power jack on the instrument. Find the power switch on the rear panel and turn the instrument on. The green LED "on" indicator and the LCD display backlighting should illuminate.

Allow at least 1/2 hour warm-up. More than 1 hour is preferred if time permits. Initial PPM readings may start out high and possibly drop to zero for a few minutes. Then the readings will tend towards the actual value as the systems settles into equilibrium.

The compact, high-speed sample pump in the instrument makes a buzzing sound. This is normal.

Connect your sample feed tubing to the instrument's 1/4" input compression fitting or via a small optional sample line filter. The Tygon feed tubing is Teflon lined polyethylene so that the ozone is flowing through Teflon, but the tubing is more flexible than pure Teflon. The range is selected automatically by the instrument unless it is set to a preferred range by the Function control on the front panel. See further instructions on Range Selection below.

Front Panel



Back Panel

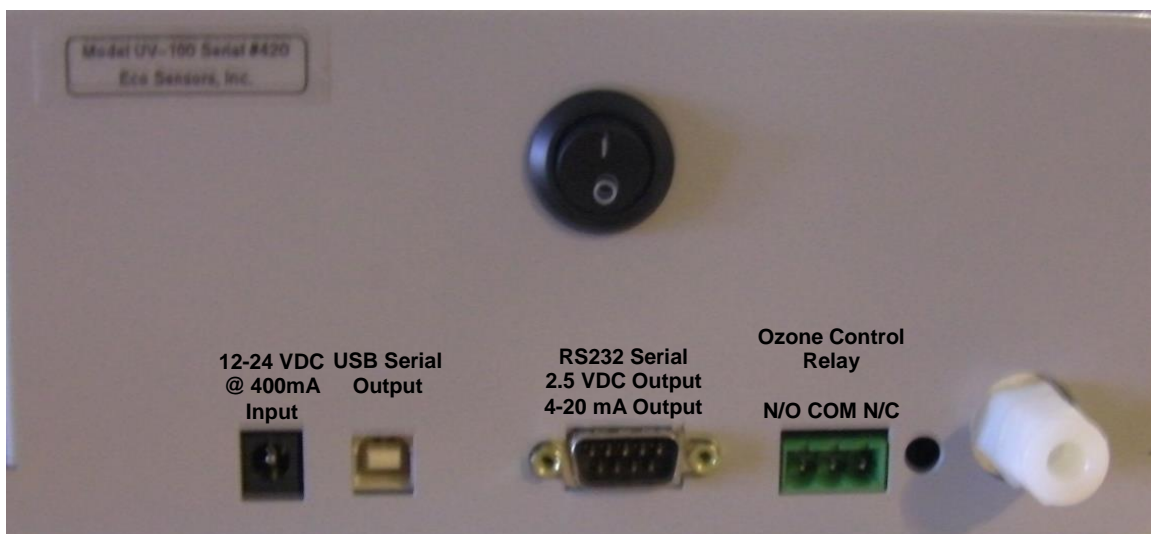

Use only the sample air filter supplied with the instrument. Other filters, especially those with a greater pressure drop, can materially affect the readings. This will be noticed if the instrument's zero is significantly above 0 ppm with no ozone present.

DATA READOUT

Ozone readings are displayed continuously on the panel liquid crystal display (LCD). The displayed data is updated every 10 seconds. Voltage, current loop, and digital outputs on the rear panel are described in Outputs to External Equipment below.

FUNCTION CONTROL

The panel Function Control is to access the internal microprocessor. The knob is gently but firmly pushed in, held there until a response is seen in the LCD display, released, turned to select a function, and then pressed momentarily to activate the selected function.

MENU SECTIONS

Upon start up, the UV-100 will display software version number then date and time.

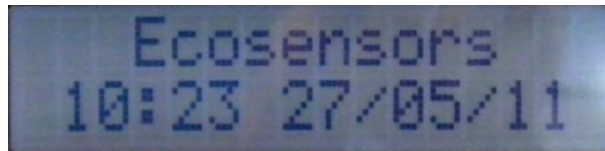

Pressing the function knob will open the main menu.

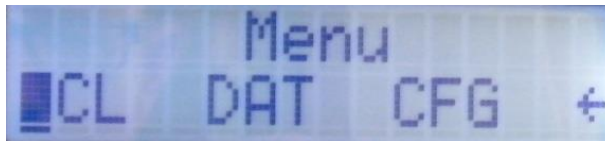

Scale (SCL) Menu:

Pressing the function knob again enters the scale menu.

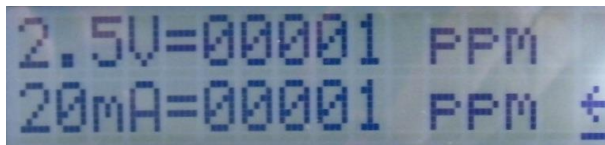

The UV-100 independently controls the 0-2.5 VDC and 4-20mA scales. This feature is very useful in multi-level control applications. See the Application Examples section for more information.

The scale can be set to full scale = to 1 PPM to 999 PPM. Setting the scale maximum near the normal operational Ozone levels will better resolution at lower readings. Selecting the <- arrow returns to the previous menu.

NOTE: The SCL function affects ONLY the analog output (0-2.5V and 4-20mA). This display always reads 0.00-999 ppm.

Data (DAT) Menu:

The Data menu controls the internal logging feature of the UV-100. The UV-100 can store approximately 36 hours of readings. For long term data logging techniques see the Application Examples section.

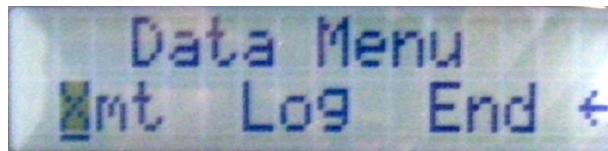

To begin logging, select LOG. You will be prompted to overwrite and data already stored.

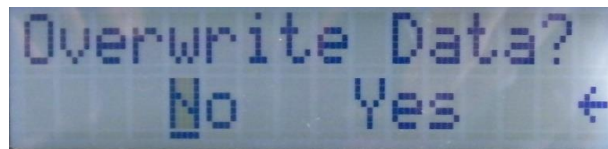

The UV-100 will now store all readings at 10 second intervals until internal memory is filled. The data is retained even if the unit is powered down or unplugged so the UV-100 can be used remotely and returned to a computer for download.

END command stops storage of measurements. Data will be kept in memory until an Overwrite command is given.

Output

To connect the UV-100 to the computer, refer to Connections To External Equipment section.

To download, connect the UV-100 to a computer and select XMT. The UV-100 will output all measurement records in memory in a comma delimited serial stream.

Output Examples:

Normal Mode:

```
0.00,298.4,575.8,09:34:38,27/05/2008
0.00,298.4,575.8,09:34:48,27/05/2008
0.04,298.4,575.7,09:34:58,27/05/2008
0.02,298.4,575.8,09:35:08,27/05/2008
0.03,298.4,575.8,09:35:18,27/05/2008
0.03,298.4,575.8,09:35:28,27/05/2008
0.03,298.4,575.8,09:35:38,27/05/2008
0.03,298.4,575.8,09:35:48,27/05/2008
0.03,298.4,575.8,09:35:58,27/05/2008
```



↑
Ozone Temperature (Kelvin) Date (DD/MM/YYYY)
Pressure (Torr) Time (24H)

Logging Mode:

Logging Started
1,0.00,298.4,575.7,09:39:29,27/05/2008
2,0.00,298.4,575.8,09:39:39,27/05/2008
3,0.00,298.4,575.8,09:39:49,27/05/2008
4,0.07,298.4,575.8,09:39:59,27/05/2008
5,0.02,298.4,575.8,09:40:09,27/05/2008
6,0.03,298.4,575.8,09:40:19,27/05/2008
7,0.03,298.4,575.8,09:40:29,27/05/2008
8,0.03,298.4,575.8,09:40:39,27/05/2008

↑
Sample Number

Configuration (CFG) Menu:

Use to set the relay set points and date and time.



Relay:



The relay set points are used to control a variety of external equipment such as Ozone generators, circulation fans, indicator lights and alarms.

CAUTION: The relay is rated at 240V and 5A. For controlling large motors and other heavy electrical loads a power relay will need to be cascaded off the UV-100's internal relay.

Date and Time Adjust (D/T):



Time is in 24 hour format. Date is in DD/MM/YYYY format.

CALIBRATION

The Eco Sensors, Inc., UV-100 is calibrated to a reference instrument whose calibration is traceable to the US government standards agency, NIST. The UV-100 has internal sensors and programming to correct its calibration for temperature and pressure. Calibration data and date for your UV-100 are included in the document package included with the instrument.

Recalibration can be done simply and quickly at Eco Sensors, Inc.

IMPORTANT NOTE: The calibration of the UV-100 is pressure (P) and temperature (T) compensated. Many other UV analyzers on the market are not P and T compensated even though their calibration is certified as traceable to an international standard. The major difference that will be observed from the lack of P and T compensation is at high altitudes the UV-100 will read a higher ozone concentration inversely proportional to the barometric pressure at the higher altitude versus the barometric pressure at sea level. A convenient formula for approximating the correction for Ozone analyzers other than the UV-100 is:

For every 1,000 meters of altitude, add 14% to the uncorrected reading.
For every 1,000 feet of altitude, add 5% to the uncorrected reading.

PANEL LED INDICATORS

>0.1 PPM: Reading is above the OSHA Limit for 8 hour exposure to Ozone

Low Flow: Input sample draw is less than the average of 1 Liter/Min. Check inlet tubing and filter for obstruction.

Low Lamp: Lamp output is below normal levels. This is normally caused by internal contamination or fault in the lamp or lamp circuitry. Contact our Technical Support if this light turns on.

Power: UV-100 is powered and operating.

TRANSMITTING DATA TO COMPUTER

Data from the UV-100 is easily transmitted to the PC using the Microsoft Windows® operating system. The program used for this is HyperTerminal found in Windows XP and previous versions. For Windows 7 a third party terminal program will have to be installed. Shareware sites such as www.download.com have free terminal emulator programs for Windows 7. To set up the PC to receive and display UV-100 data, see the procedure shown in Appendix A.

OUTPUTS TO EXTERNAL EQUIPMENT

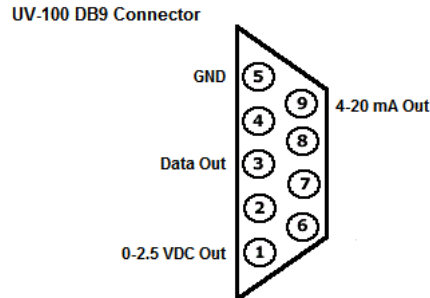

0-2.5 volts DC: (2.5V = full ppm scale) Pins 1 and 5 of the RS-232 connector.

4-20 mA: (4 mA = 0 ppm, 20 mA = full scale) Pins 9 and 5 of the RS-232 connector.

Data output via RS-232 Connector: This output is ozone concentration in PPM, temperature, pressure, and time and date sent in ASCII via the RS-232 connector on the rear panel of the UV-100. This can be directly connected to the serial COM port of many computers.

Direct USB Output: Data is also available via the USB port on the rear panel of the UV-100. A CD disc with drivers for Windows Vista, Windows XP and Windows 7 are included in this shipment or can be emailed to you by our tech support department. Set up is shown in Appendix B. Output is shown as ozone concentration (PPM), temperature in degrees K, pressure in Torr, and time and date. Some computers will find an already existing USB driver installed that will accept the UV-100 USB output. Due to the many variations of operating systems in use, if you have problems installing or using the drivers on our disc, contact Tech Support at Eco Sensors (tech@ecosensors.com).

Set Point Relay Contacts: A wiring plug is provided to enable component control via relay. Refer to Appendix X for application examples using this relay.

SERVICE AND MAINTENANCE

There are no user serviceable parts in this instrument. **Opening the enclosure will void the warranty.**

Filter/Input: The input sample tubing filter is recommended for any operational environment. A length of Tygon TE-200 Teflon coated tubing and a disposable micromesh disk filter is provided. It is recommended that the input filter is replaced at 6 month intervals, more often in dusty and more complex environments.

In severe condensing humidity environments a small moisture trap may be needed on the input to protect the UV-100's internal tubing from condensing moisture internally. Contact Technical support (tech@ecosensors.com) for more information.

AC ADAPTER

For use in North America and other areas with 120 V 60 HZ, the Eco Sensors P-20 adapter should be used. For other areas adapters should be purchased locally that fit

local wall sockets and conform to local codes. The output should be 12 volts DC unregulated, 500 mA. The plug to our instrument should fit a 5.5/2.5 mm socket with the center pin +. For further details see our Tech Note P-102.

SPECIFICATIONS

Sensor: Narrow band filter to UV detector at 254 nm.

Sensitivity: First responds at approximately .01 ppm

Accuracy: 0-100 ppm, 2 %. 100-999 ppm 5%

Response time: Within one minute of when gas reaches the sensor

Temperature and humidity range: 10-40 deg C and 0-80% relative humidity.

Fuse: Self-resetting. Not user replaceable.

Filter (sample inlet): 30 micron disposable.

Supply voltage required: 12-24 volts DC, 500 mA.

Size of instrument (HXWXD): 95 X 210 X 216 mm (3 3/4" X 8 1/4" X 8 1/2").

Weight of instrument: 2.1 kg (4.7 lbs.).

PRECAUTIONS

- Allow at least 30 minutes warm-up.
- Read all instructions in this manual.
- Keep instrument dry. Never let water or other liquids into the sensor.
- Do not drop the instrument or subject it to continuous vibration.
- Do not store in high levels of dust.
- Do not clean the instrument with cleaning chemicals or solvents. Clean it with a damp cloth.
- Do not operate near heavy aerosols (spray) usage or where oxygen is being administered.
- Call a qualified electrician if you have any doubts about voltages, currents, electrical practice, etc.
- While not necessary for typical uses, for highest precision results in electrically noisy locations, the instrument should be grounded to earth to achieve maximum stability.

WARRANTY

This product is warranted against defects in materials and workmanship for one year following the date of purchase by the original owner. This warranty does not include damage to the product as a result of misuse, accident, damage, modifications or alterations, and it does not apply if the instructions in this manual are not followed. If a defect develops during the warranty period, Eco Sensors at its election will repair the instrument or replace it with a new or reconditioned model of equivalent quality. In the event of replacement with a new or reconditioned instrument, the replacement unit will continue the warranty of the original unit.

To return the instrument contact your distributor, or call Eco Sensors at (800) 472-6626 or e-mail at sales@ecosensors.com to receive return instructions and a Return Material Authorization (RMA) number. Except as provided herein, Eco Sensors makes no warranties, express or implied, including warranties of merchantability and fitness for a particular purpose. Eco Sensors shall not be liable for loss of use of this instrument or

other incidental or consequential damages, expenses or economic loss, or claims for such damage or economic loss.

RECORD YOUR SERIAL NUMBER HERE _____

KEEP THIS MANUAL AND WARRANTY FOR YOUR RECORDS.

Eco Sensors is a registered trademark of Eco Sensors, Inc.

© Eco Sensors, Inc. 2004. Revision 08/11

For brochures, application and tech notes, and other useful information, visit our extensive website at www.ecosensors.com. E-mail us at sales@ecosensors.com.

APPENDIX A

RS232 SERIAL DATA SETUP AND READOUT EXCLUDING WINDOWS 7

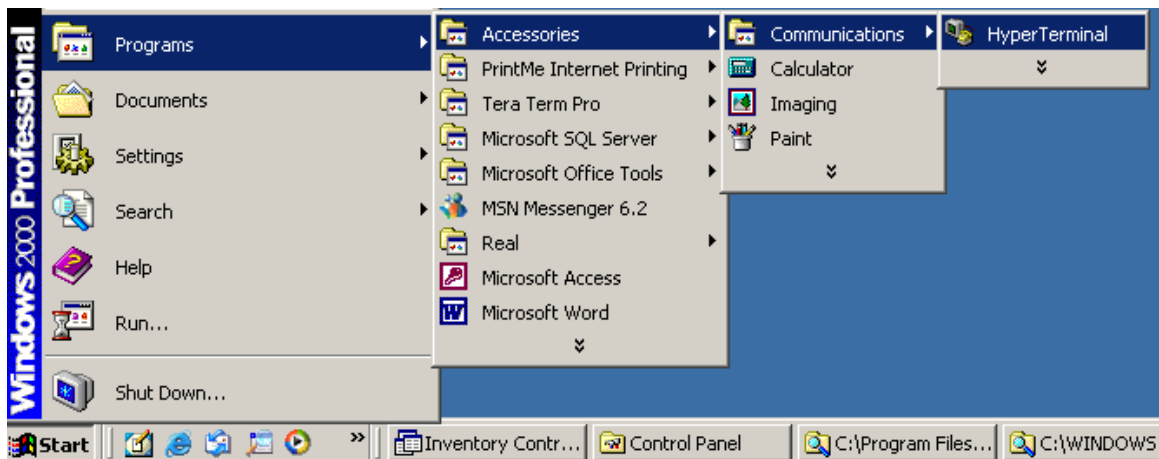

1. Open HYPERTERMINAL from the ACCESSORIES folder of the PROGRAMS directory.

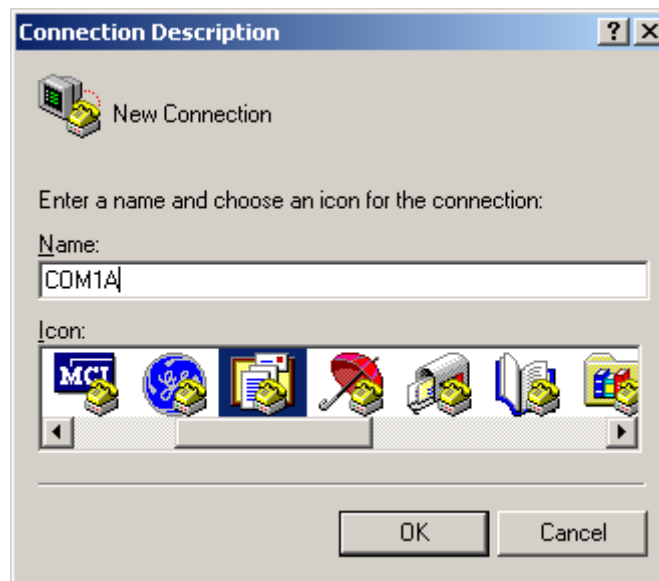

2. You will be asked for a CONNECTION DESCRIPTION. Click OK.



3. Choose which port you will use to connect to the computer. The default serial COM port on most PC computers is COM1. Click OK.

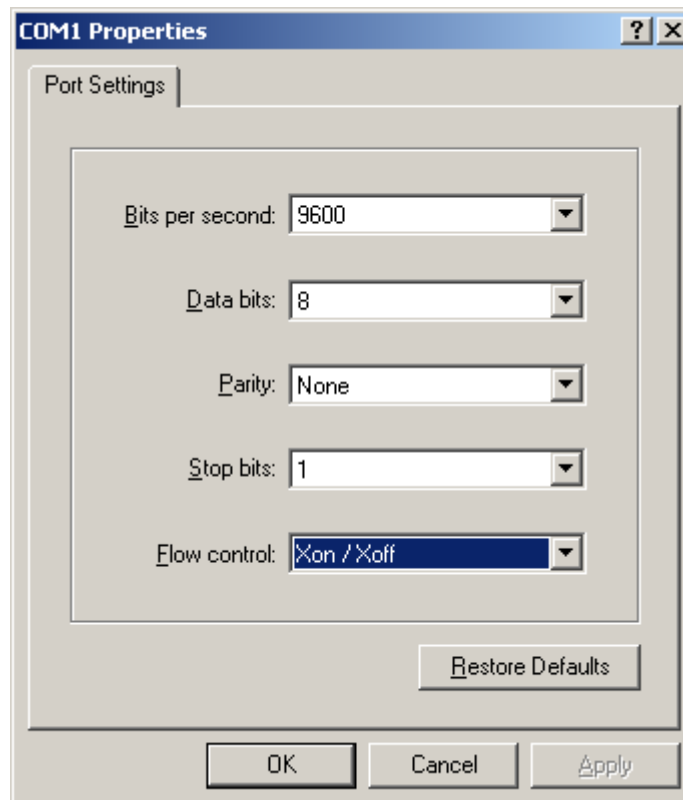

4. Enter PORT SETTINGS as above: Bits per second – 9600 data rate, Data bits - 8,

Parity - None, Stop bits - 1, Flow control - XON/XOF. Click OK.

RS232 SERIAL DATA SETUP AND READOUT FOR WINDOWS 7

Windows 7 does not include a terminal program. Third party shareware programs such as TerraTerm are available from websites such as www.download.com. These programs vary in operation slightly but the procedure is approximately the same as above.

If a Windows XP installation disk is available, Hyperterminal can be transferred to Windows 7. Copy hyperterm.exe from Program Files\Windows NT directory and hyperterm.dll from the Windows\System32 directory of the Windows XP disk to

APPENDIX B

UV-100 USB DIRECT CONNECT PROCEDURE

Items:

- UV-100
- USB Cable
- PC Computer with Windows 2000, Vista or XP
- USB to UART Driver Disk

1. Install USB to UART Driver Disk in the computer's CD ROM drive.
2. With the UV-100 off, attach USB cable from UV-100 to a USB port on the computer.
3. Turn on UV-100.
4. The computer should recognize the USB connection



5. Select the "Install from a specific location" option.
6. Navigate to the CD ROM drive.



7. Run the Installation wizard.

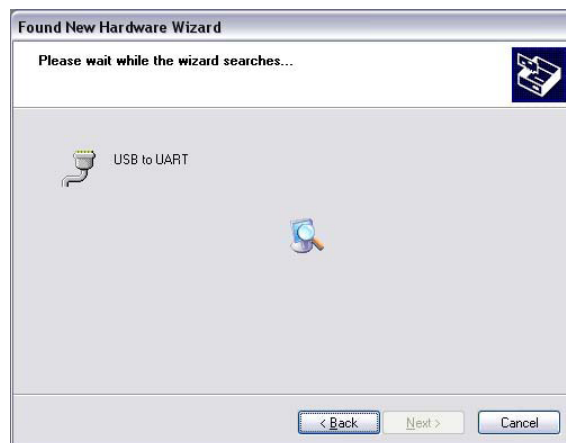

8. Finish the driver installation.



9. Refer to Appendix A for connection steps via Hyperterminal or other terminal programs.

APPENDIX C

PINOUT OF DB9 CONNECTOR

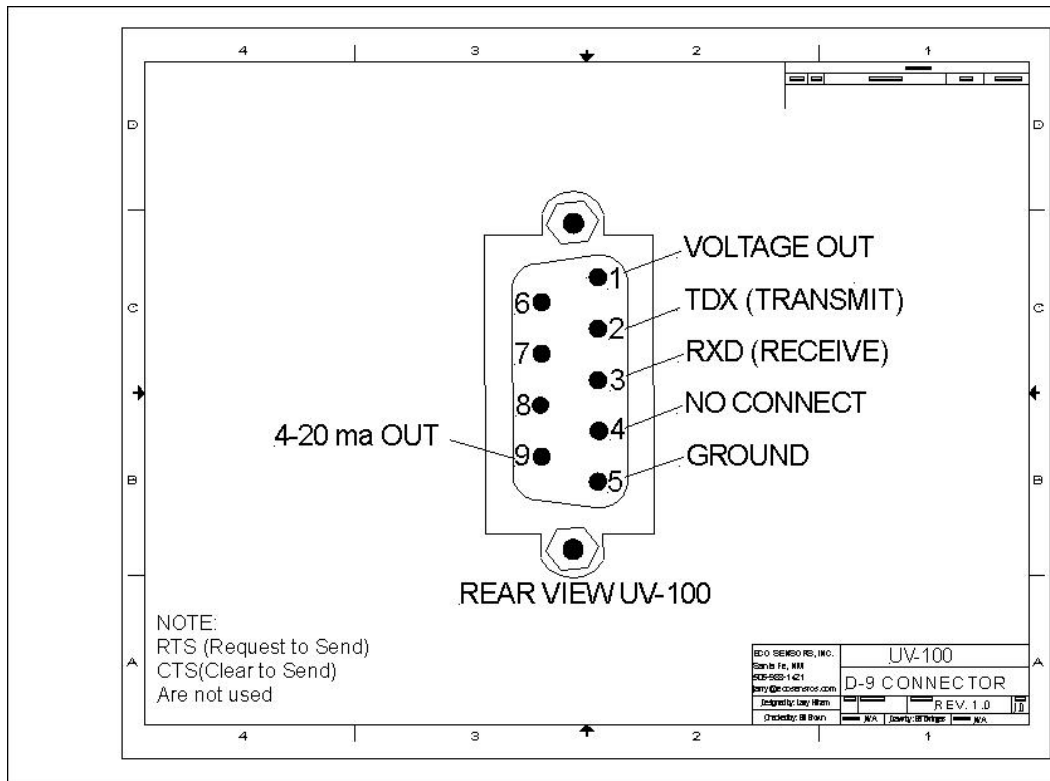

APPENDIX D

APPLICATION EXAMPLES

Here are 3 widely used examples installed by many users of the UV-100. These are shown **for reference only**; for more details contact Eco Sensors Tech Support.

REMEDIATION EXAMPLE

Ozone's cleaning and disinfecting properties are well known. Its ability to break down bacteria and a wide range of contaminants with almost no residue is just beginning to be used in real-world applications. The following is an example of one of Eco Sensor's Customer setup to remove mold from rooms and combined spaces in flooded homes:

Items:

- UV-100

- Ozone generator(s) (UV 550 Pro or similar)
- Power relay (s) for generator and fan (optional)
- Indicator light for OSHA limit
- 4-20 mA current loop

To destroy mold the space is held at a very high Ozone level for a predetermined amount of time. The generator is controlled using the set point relay on the back of the UV-100 to hold Ozone.

After the Ozone “dwell” interval is complete, generator power is shut off or UV-100 generator ON level is set to zero. Over the course of a few hours the Ozone will decay to zero. In this particular installation an indicator light was tied to the 4-20 mA output to give an “all clear” indication when the space was reading under the OSHA immediate limit of 0.3 PPM. 4-20 mA scale is set to 4 mA = 0 PPM, 20 mA = 1 PPM.

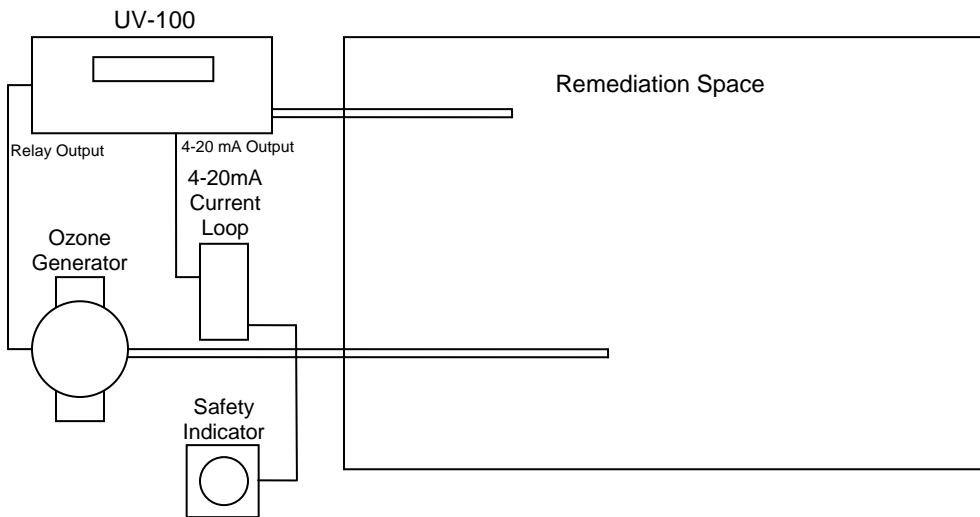

COLD CONDENSING EXAMPLE

Items:

- UV-100
- Tygon SE-200 Teflon lined tubing, length variable
- Small moisture trap
- Ozone generator (if Ozone control is required)

In some applications the environment under measurement is outside the temperature and/or humidity range of the UV-100. Several methods can be used to shield the UV-100 from these extremes.

The UV-100 is kept isolated by being outside the cold space and by using a long length of inlet tubing, the majority of which coiled outside the cold space. This allows for the inlet sample to be warmed to an acceptable level before measurement.

Condensation from the temperature change is eliminated using a small moisture trap spliced into the inlet line.

Due to the extra length of inlet tube and moisture trap, offsets will need to be made for measurements. The reading will be delayed depending on the length of tube, as much as an extra minute or more. Testing with high Ozone pulses can determine this delay.

The reading will also be attenuated as much as 5% due to the inlet length and loss from the moisture trap.

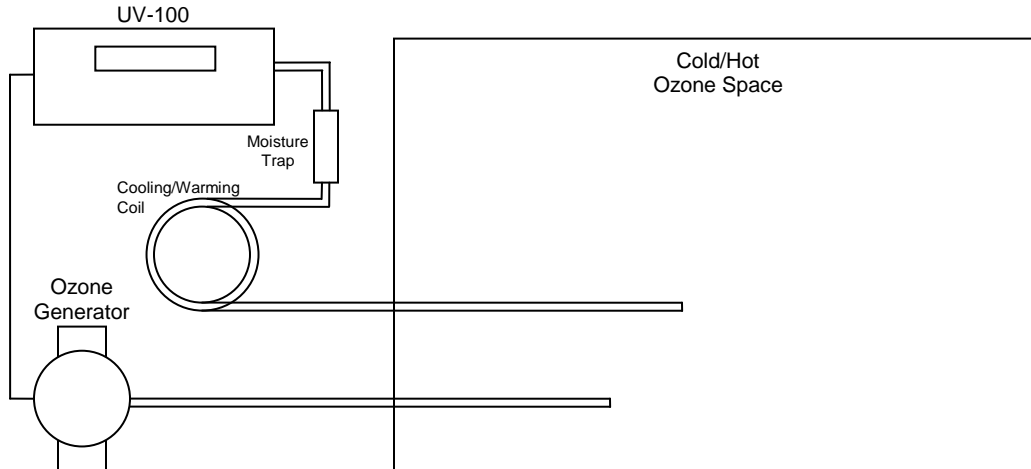

LONG TERM DATA LOGGING EXAMPLE

The internal memory for data storage for the UV-100 is limited to approximately 36 hours. For long-term logging the best method is voltage data logging using the Eco Sensors DL-3 and the 0-2.5 VDC output on the 9 pin connector.

Items:

- UV-100
- Computer
- Eco Sensors DL-3 Voltage Data Logger
- D9 cable with pin breakout
- HOBO Data Logger Software

Wiring:

A DB9 connector with discreet wiring will be needed to connect the DL-3. The 0-2.5V output on the D9 Connector (Pin 1 +V, Pin 5 GND) is connected to a mini stereo jack to one channel of the DL-3. Custom DL-3 voltage cables can be purchased from Eco Sensors as an option with the DL-3.

The DL-3 has 4 channels that could be used to log multiple UV-100's or other parameters such as temperature and relative humidity.

UV-100 Scaling:

Set the 0-2.5 VDC scale to the anticipated maximum Ozone level in the measurement environment. This will give the highest possible resolution to the Voltage output for logging.

DL3 Scaling:

Install the the HOBOWare software supplied with the DL-3 and connect the DL-3 to a computer using the USB cable. Set input type for channel 1 to Voltage, scale to 0 VDC = 0 PPM and 2.5 VDC = to the scale value in the UV-100. For further details about HOBOWare setup contact technical support.

APPENDIX E

THEORY OF OPERATION

The Eco Sensors Ozone Monitor is designed to enable accurate measurements of indoor ozone over a wide dynamic range extending from a limit of detection of .01 ppm by volume (ppmv) to an upper limit of about 1,000 ppm based on the well established technique of absorption of ultraviolet light at 254 nm. The Ozone Monitor is light weight (4.7 lb., 2.1 kg.) and has low power consumption (~5 watt) relative to conventional instruments and is therefore well suited for applications such as:

- Industrial hygiene monitoring where ozone may be present in the workplace.
- Control of ozone generators and systems.
- Research and quality checking of ozone emitting equipment.
- Monitoring high ozone concentrations such as process off-gassing.

Theory of Operation

Absorption of UV light has long been used for measurements of atmospheric ozone with high precision and accuracy. The ozone molecule has an absorption maximum at 254 nm, coincident with the principal emission wavelength of a low-pressure mercury lamp. Fortunately, few molecules found at significant concentrations in the atmosphere absorb at this wavelength. However, interferences, such as organic compounds containing aromatic rings, can occur in highly polluted air.

Figure 1 is a schematic diagram of the ozone monitor. Ozone is measured based on the attenuation of light passing through a 6.2 cm long absorption cell fitted with quartz windows. A low-pressure mercury lamp is located on one side of the absorption cell, and a photodiode is located on the opposite side of the absorption cell. The photodiode has a built-in interference filter centered on 254 nm, the principal wavelength of light emitted by the mercury lamp. An air pump draws sample air into the instrument at a flow rate of approximately 1 L/min. A solenoid valve switches so as to alternately send this air directly into the absorption cell or through an Ozone scrubber and then into the absorption cell. The intensity of light at the photodiode is measured in air that has passed through the Ozone scrubber (I_o) and air that has not passed through the

scrubber (I). Ozone concentration is calculated from the measurements of I_o and I according to the Beer-Lambert Law:

$$C_{O_3} = \frac{1}{\sigma l} \ln\left(\frac{I_o}{I}\right)$$

Where l is the path length (6.2 cm) and σ is the absorption cross section for ozone at 254 nm (1.15×10^{-17} cm² molecule⁻¹ or 308 atm⁻¹ cm⁻¹), which is known with an accuracy of approximately 1%. The Eco Sensors instrument uses the same absorption cross section (extinction coefficient) as used in other commercial instruments.

The logarithm of equation 1 is approximated in the microprocessor of the instrument with sufficient accuracy to provide five orders of dynamic range; ozone mixing ratios are measured up to 1,000 ppmv, as compared to 1 ppmv for most commercial ozone instruments.

The pressure and temperature within the absorption cell are measured so that the ozone concentration can be expressed as a mixing ratio in parts-per-million by volume (ppmv). In principle, the measurement of ozone by UV absorption requires no external calibration; it is an absolute method. However, non-linearity of the photodiode response and electronics can result in a small measurement error. Therefore, each instrument is compared with a NIST-traceable standard ozone spectrophotometer in the laboratory over a wide range of ozone mixing ratios. These results are used to calibrate the Ozone Monitor with respect to an offset and slope (gain or sensitivity). Calibration data is supplied with the instrument. It is recommended that the instrument be recalibrated at least once every year and preferably more frequently. The offset may drift due to temperature change or chemical contamination of the absorption cell. An accurate offset correction can be measured from time to time using the ozone scrubber ("zero ozone filter") available for use with the instrument.

Basic UV Instrument System

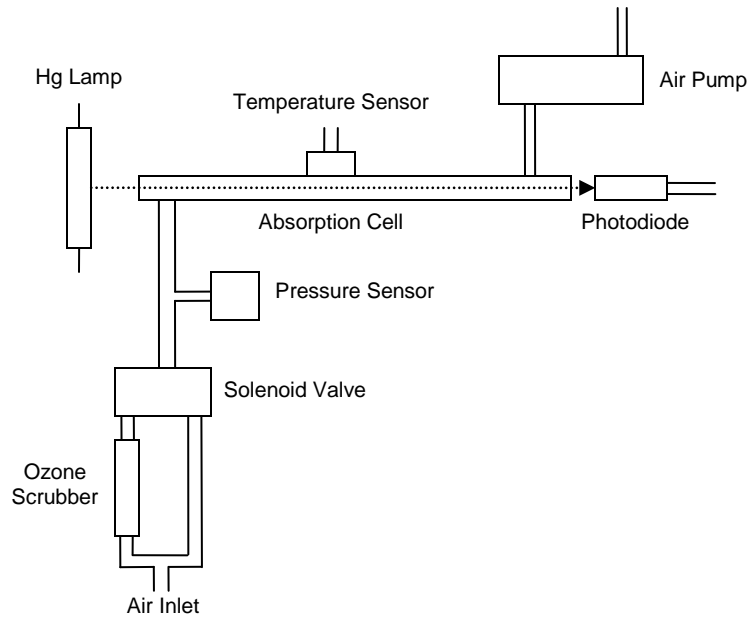

OPTIONS Available for UV-100

Pelican case PN 20-0598	\$ 180.00
Hi Efficiency Sample Line Filter and Housing PN FLTRS(LARGE)	\$ 126.00
Hi Efficiency Sample Line Filter Elements 10pcs PN FILTERPAK(LARG)	\$ 63.00
Heavy Duty External Pump(replaces internal pump) PN EXT PUMP(HD)	\$ 440.00
C Type Power Plug 240 VAC 50Hz Adapter	\$ 75.00